

HITACHI EX8-2B

Hitachi Construction Machinery (Europe) NV
Siciliëweg 5, Haven 5112, 1045 AT Amsterdam, The Netherlands
T +31-(0)20 44 76 700, F +31-(0)20 33 44 045, www.hcme.com



HITACHI

Specifications and dimensions

EX8-2B

Weight	810 kg
Engine	Kubota Z482-B
Rated Engine HP (DIN 6271)	6.4 kW (8.7 PS) at 2 450 rpm
Piston Displacement	0.482 l
Fuel Tank Capacity	10 l
Travel speed	0 - 2.0 km/h
Swing speed	9.2 rpm
Gradeability	30° / 58%
Arm Crowd Force	5.8 kN
Bucket Digging Force	9.6 kN
Boom Swing Angle	LH 90° / RH 50°
Hydraulic System – Pumps	2 x gear pump
Max. Oil Flow	2 x 9.7 l/min
Operating Pressure	175 kgf/cm ²
Tank Capacity	12 l
Undercarriage Total Width	720 / 900 mm (adjustable)
Undercarriage Total Length	1 225 mm
Shoe Width	180 mm
Dozer Blade W x H	720 / 900 x 230 mm
Blade Working Radius	150 mm (height) – 175 mm (depth)

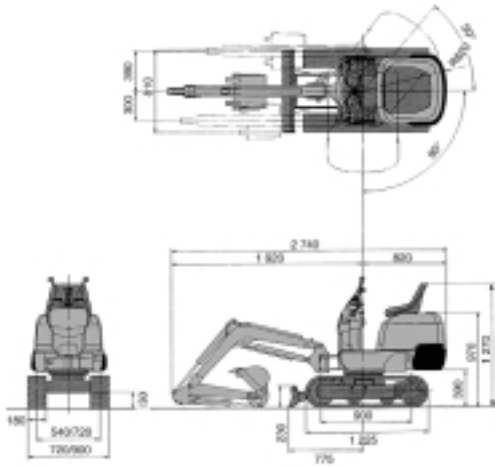

Working range

Arm Length	700 mm
Max. Digging Depth	1 525 mm
Max. Digging Reach	2 800 mm
Max. Dumping Height	2 035 mm
Max. Cutting Height	2 800 mm

